

D12 Amplifier

Hardware manual (4.3 EN)



WARNING!

References in the manual

This refers to a potentially dangerous situation which may lead to personal injury.

CAUTION!

This refers to a potentially dangerous situation which may lead to personal injury.

IMPORTANT!

This refers to a situation which may cause the equipment to malfunction.

Note: Additional information.

Symbols on the equipment



Please refer to the information in the operating manual.



WARNING!
Dangerous voltage!

General Information

D12 Amplifier
Hardware manual

Version 4.3 EN, 04/2007, D2012.E.04

Copyright © 2007 by d&b audiotechnik AG ; all rights reserved.

Keep this manual with the product or in a safe place so that it is available for future reference.

d&b audiotechnik AG
Eugen-Adolff-Strasse 134, D-71522 Backnang, Germany
Telephone +49-7191-9669-0, Fax +49-7191-95 00 00
E-mail: docadmin@dbaudio.com, Internet: www.dbaudio.com

Contents

1. Safety precautions.....	5
1.1. Information regarding use of the D12 Amplifier.....	5
2. Introduction.....	6
2.1. Scope of supply.....	6
3. D12 Amplifier.....	7
3.1. D12 based systems.....	7
3.2. D12 block diagram.....	7
3.3. Digital signal processing.....	8
3.4. D12 power amplifiers.....	9
3.5. SenseDrive.....	9
3.6. Power supply.....	10
3.6.1. Inrush current limiter.....	11
3.7. Fan.....	11
3.8. Remote control.....	11
4. Controls and indicators.....	12
4.1. Controls.....	12
4.1.1. Mains power switch [1].....	12
4.1.2. MUTE switch (A/B) (green LED) [2].....	12
4.1.3. LEVEL/PUSH MENU (Digital rotary encoder) [3].....	13
4.2. Indicators.....	14
4.2.1. LC Display [4].....	14
4.2.2. ISP LED (A/B) - Input Signal Present (green) [5].....	14
4.2.3. GR LED (A/B) - Gain Reduction (yellow) [6].....	14
4.2.4. OVL LED (A/B) - Overload (red) [7].....	14
5. Connections.....	15
5.1. Mains panel.....	15
5.1.1. Mains power connection [8].....	15
5.1.2. Fuse protection [9 (a/b)].....	15
5.1.3. REMOTE [10].....	16
5.1.4. SERVICE [11].....	16
5.2. Connector panel (I/O Panel).....	17
5.2.1. INPUT A/B [12] and LINK A/B [13].....	17
5.2.2. INPUT DIGITAL AES/EBU [14a] and LINK [14b].....	17
5.2.3. OUT A/B [15 (a/b/c)].....	17
5.2.4. D12 I/O modes.....	17
5.2.4.1. Dual channel mode.....	18
5.2.4.2. Mix TOP/SUB mode.....	18
5.2.4.3. 2-Way Active mode - Single input.....	19
5.2.5. Loudspeaker wiring.....	19
5.2.5.1. Loudspeaker pin assignments and equivalents....	20
6. Installation and operation.....	21
6.1. Installation.....	21
6.2. Operation.....	21
6.2.1. Power consumption and power loss.....	21
6.2.2. Operating conditions.....	22
6.2.3. Mains supply.....	23
7. Technical specifications.....	24

7.1. Technical drawings.....	26
8. Declarations.....	27
8.1. EU declaration of conformity (CE symbol).....	27

1. Safety precautions



WARNING!

1.1. Information regarding use of the D12 Amplifier

The following information is intended to prevent fires and possible electric shocks:

The D12 is a protective class 1 unit. Make sure that the earth (ground) contact is attached when the unit is in operation. A missing earth (ground) contact may lead to dangerous voltages in the housing and controls.

Never connect an amplifier output pin to any other in or output connector pin or earth (ground). This might damage the unit or lead to electric shock.

Lay all cables connected to the unit in a way that they cannot be crushed by vehicles or other equipment and that no one can step on them.

Keep dust, moisture, water or other liquids well away from the unit. Do not put any kind of objects filled with liquids (e.g. Drinks) onto the unit.

Please ensure the mains connector is accessible in any time to disconnect the unit in the case of malfunction or danger.

Never operate the unit when it is open. Always disconnect the mains power supply when replacing a defective fuse. Only use the type of fuse listed in the specifications.

Only carry out work specified in this manual and always disconnect the mains power supply. Even the mains power supply is disconnected electrical charge remains to several electronic components. After 15 min. the respective components will be discharged.

All other work should be performed by trained service staff, especially in the following cases:

- Mains power cable, socket or plug has been damaged
- Objects or liquids have entered the unit
- The unit is not operating normally
- The unit was dropped or the housing is damaged

IMPORTANT!

The device complies with the electromagnetic compatibility requirements of EN 55103 (product family standard for audio, video, audio-visual and entertainment lighting control apparatus for professional use) for the environments E1 (residential), E2 (business and commercial), E3 (outdoor use in urban areas) and E4 (outdoor use in rural areas).

Acoustic interference and malfunctions may occur if the unit is operated in the immediate vicinity of high-frequency transmitters (e.g. wireless microphones, mobile phones, etc.). Damage to the unit is unlikely, but cannot be excluded. To meet the EMC requirements, use only shielded cables with properly connected plugs for all input signal terminals.

2. Introduction

This manual describes the facilities and functions of the hardware of the d&b D12 amplifier.

A detailed description of the D12 Software and remote control is given in the D12 Amplifier Software manual, which is also provided with the D12 Amplifier.

A number of publications with supplementary information on our products are available from the Documentation section of our website at www.dbaudio.com. You can either download these directly or use the online order form to request a printed version.

If the document you want is not detailed on the form please enter the title in the box after entering your address information.

2.1. Scope of supply

Initial inspection

Before starting up the following inspections should be carried out:

- Please verify the shipment for completeness (refer to the table below - Tab. 1).
- Please carry out a visual inspection of the packaging, the D12 unit and the power cord for obvious damage during shipment.

For any sign of damage or incompleteness to the items listed in the table below please contact your local dealer from whom you received the unit.

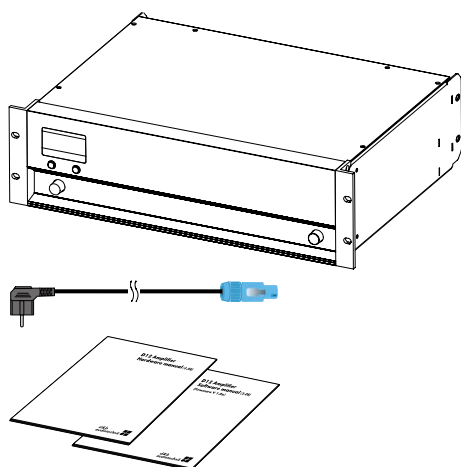

Fig. 1: D12 Amplifier, scope of supply

Quantity	d&b Code	Description
1	Z2600	D12 Amplifier, dependent on chosen output option (EP5, NL4 or NL8 output connectors)
1	Z2610	Power cord D12 CEE (specific to country)
1	D2012.E	D12 Amplifier, Hardware manual
1	D2013.E	D12 Amplifier, Software manual

Tab. 1: D12 amplifier, included in delivery

3. D12 Amplifier



Fig. 2: D12 Amplifier

3.1. D12 based systems

The d&b D12 amplifier is a two channel power amplifier that incorporates digital signal processors (DSP) providing loudspeaker specific controller functions. It is designed for use with all current d&b loudspeakers, and a linear mode is available.

The D12 is designed with both digital and analog signal inputs, loudspeaker outputs, and has remote control and monitoring capabilities.

The switch mode power supply will function with a variety of mains voltages and allows less weight at high output power.

The level control on the front panel incorporates a digital rotary encoder, which enables selection of all operating modes in conjunction with a Liquid Crystal Display (LCD). The D12 includes complete signal processing, all necessary protection circuits, a REMOTE and SERVICE interface, all connectors and status indicators.

The D12 is housed in a 19" x 353 mm (13.9") 3 rack unit enclosure made from stainless steel with an extruded aluminium front panel.

3.2. D12 block diagram

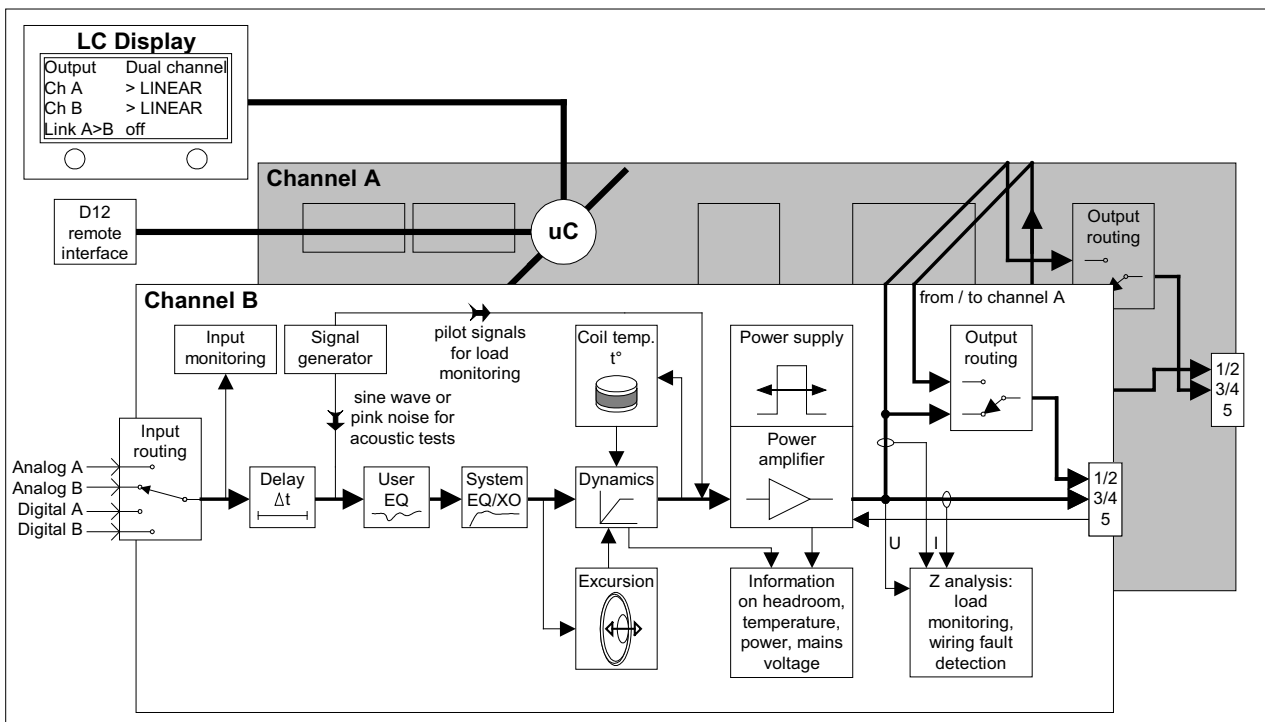

Fig. 3: D12 Amplifier block diagram

3.3. Digital signal processing

The digital signal processing provides loudspeaker specific set ups that are selected using the front panel controls. These set ups include all loudspeaker equalization and protection functions.

A 4-band parametric equalizer is incorporated in each channel to provide optional Boost/Cut or Notch filtering. A signal delay capability also allows delay settings of up to 340 msec. (= 100 m/328.1 ft) to be applied independently to either channel.

A signal generator offering pink noise or sine wave program can be selected from the front panel controls.

Each unit can be given a unique Device Name to simplify identification and a password protected LOCK function is also incorporated to inhibit unauthorized set up changes.

IMPORTANT!

System configurations are specific to the characteristics of each loudspeaker and affect the frequency response and maximum output level. To ensure optimum performance and prevent damage to system components each type of loudspeaker has to be used in conjunction with a suitably configured D12.

The D12 digital signal processing circuits introduce a processing delay of 0.3 msec. into the signal path. If two identical loudspeakers are driven by different controllers the respective delays of the units used have to be considered (D12 = 0.3 msec., E-PAC = 1.0 msec. and A1/P1200A no delay). The D12 effectively positions its respective loudspeaker at a distance of 24 cm (0.79 ft) in front of a loudspeaker driven by the E-PAC and 10 cm (0.33 ft) behind a loudspeaker driven by the A1/P1200A.

Where the two loudspeakers form an array this will lead to an increase in comb filtering and unpredictable coverage patterns. If the distance between the cabinets is much greater than 1 m (3 ft) this effect becomes negligible.

Please note that all digital signal processing equipment used in the signal path will delay the signal. For example external digital equalizers have a typical processing delay of about 3 ms.

3.4. D12 power amplifiers

The two power amplifiers fitted to the D12 can deliver 2 x 750 W continuous sine wave power into an 8 ohms load, increasing to 2 x 1200 W continuous sine wave power into a 4 ohms load. These maximum output ratings measured with sine wave are valid for minutes only until the unit will switch into thermal protect.

IMPORTANT!

The D12 is specifically designed to produce high power into low impedance loads, typically those between 4 and 16 ohms. Please check in the relevant loudspeaker manual for the recommended maximum number of cabinets that may be driven by each channel. Due to differences in impedance response against frequency this may vary depending on the specific loudspeaker type.

Connecting and driving more loudspeakers will not damage the amplifier but will limit the quality and dynamic range of reproduced sound as the load dips below 4 ohms. Driving low impedance loads at high levels can also trigger the amplifier protection circuits for thermal or output current overload.

A D12 will normally be operated with speech or music program - complex signals where the average power requirement is below peak power. The D12 will continue to operate indefinitely when the Crest Factor is higher than 2.4, provided the device is installed to enable the heat generated to be adequately dissipated.

Note: Please also refer to section 6.2.1. Power consumption and power loss on page 21 and section 6.2.2. Operating conditions on page 22.

3.5. SenseDrive

The accuracy of a loudspeaker's signal reproduction, both level and transient response, is influenced by dynamic damping factor - the ratio of the load to source impedance.

Whilst amplifier source impedance remains constant the impedance of the cables and connectors will largely depend upon the length and type of cable used - longer cables produce greater signal losses depending on the loudspeaker impedance. The impedance of a loudspeaker will vary markedly with frequency and especially those at low frequencies. With long cable runs this impedance variation will significantly affect the system response.

With applicable d&b systems (EP5 and NL8 connectors only) d&b SenseDrive compensates for the electrical properties of the loudspeaker cable. A "sense" wire connects the signal from the LF driver back to the amplifier where it is compared and corrected to compensate for the cable losses. Signal reproduction is enhanced by delivering the correct signal to the loudspeaker terminals irrespective of the cable losses.

Note: A detailed description of the D12 SenseDrive function is given in the technical information TI 340 (d&b code D5340.E).

Not connecting SenseDrive for C-Series subwoofers (e.g. NL4 connectors) does not change the present performance of the system.

3.6. Power supply

The D12 utilizes an autosensing switch mode power supply for mains voltages 115/230 V, 50 – 60 Hz (Optional 100/200 V) and overvoltage protection.

Where voltages outside of this range are present, a self-resetting protective circuit responds quickly to isolate the internal amplifier power supply leaving only a supervisory circuit to monitor the mains voltage.

The display will clearly indicate the fault and voltage value.

The supervision circuit is self-resetting.

The associated voltage ranges and/or the guaranteed (nominal) operating ranges are listed in the following table.

Voltage range	Status
0 – 98 V	Undervoltage
98 – 134 V	110/115/120 V operation
134 – 195 V	Undervoltage
195 – 265 V	220/230/240 V operation
265 – 400 V	Overvoltage

Tab. 2: Voltage ranges 115/230 V

To prevent the D12 from cycling on and off with fluctuating mains power supply voltages, the switching thresholds are delayed and about 4% apart from the border of the voltage range (hysteresis).

Voltage range	Status
0 – 85 V	Undervoltage
85 – 117 V	100 V operation
117 – 170 V	Undervoltage
170 – 234 V	200 V operation
234 – 400 V	Overvoltage

Tab. 3: Voltage ranges 100/200 V

3.6.1. Inrush current limiter

A mains inrush current limiter provides a "soft start" and enables several D12s to be powered up at the same time without overloading the mains power supply. The maximum current drawn during the power up phase is dependant on the mains voltage, however nominal values are 5 A at 230 V and 10 A at 115 V and 100 V.

3.7. Fan

A level and temperature controlled fan is incorporated for cooling the internal components, which allows greater cooling during louder program material. The fan speed is consequently reduced during quieter passages preventing background noise interference.

If the D12 heats up a "Temp. Warning" is given out and the fan will give full cooling power permanently.

For further information please refer to section 6.1. Installation on page 21.

3.8. Remote control

The REMOTE sockets can be used with the dbCAN (CAN-Bus) interface or d&b Remote Interface Bridge (RIB) to integrate the D12 into a control and monitoring system.

Note: A detailed description of remote control via CAN-Bus is given in the technical information TI 312 (d&b code D5312.E).

4. Controls and indicators

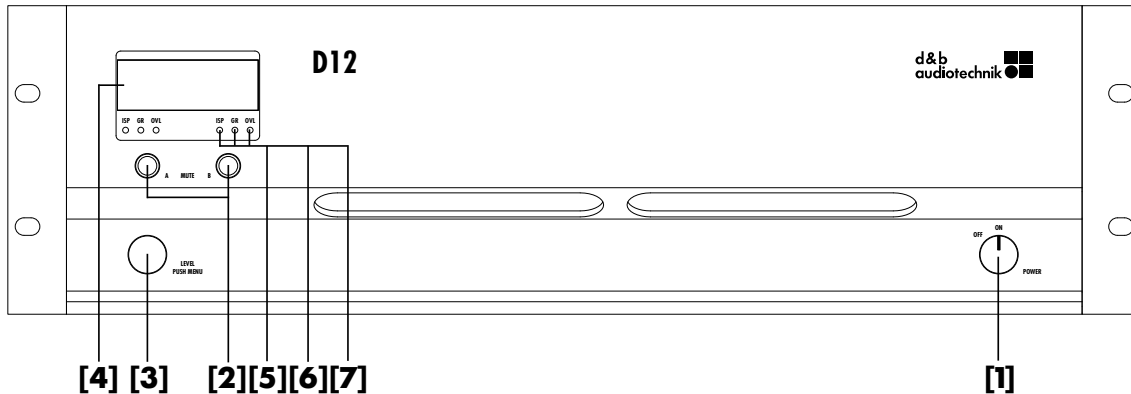

Fig. 4: D12 Controls and indicators

4.1. Controls

4.1.1. Mains power switch [1]

The on/off rotary switch is located on the right hand side at the bottom of the front panel.

- **OFF:** the D12 is isolated from the mains power supply except the overvoltage protection circuit. The power consumption is very low (2 W typical).
- **ON:** the D12 is switched on. Via remote or the MUTE A or B switch the D12 can be switched to standby mode. To indicate standby mode the display remains active.

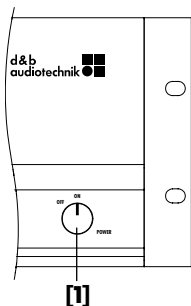

Fig. 5: D12 Mains power switch

Note: The mains power rotary switch is a "Brake-before-make contacts" type. Due to this characteristic the D12 will immediately be switched off by leaving the "ON" position.

4.1.2. MUTE switch (A/B) (green LED) [2]

When the mains power switch is set to the on position, the MUTE switch can be used to mute the respective amplifier channel or place the D12 in standby mode using the MUTE A or B switch. The switch incorporates a green LED indicator which indicates three different states - ON (unmute)/MUTE and STANDBY.

- **LED on: ON (unmuted):** the D12 is ready for use. A brief press of the MUTE (A or B) switch will mute the corresponding channel A or B. A longer press (approx. 1 sec.) of MUTE A or B places the D12 in standby mode.
- **LED regular flashing (1:1 duty cycle): ⇒ MUTE:** the corresponding channel of the D12 is muted however the power amplifiers remains powered but receiving no signal from the controller. A connected loudspeaker is therefore still damped. The channel is unmuted by briefly pressing the corresponding MUTE switch.

Note: The setting of the MUTE A/B switch is stored in the D12 when the mains power is turned off or disconnected. After switching on or reconnecting the D12 it will revert to its pre-disconnection status.

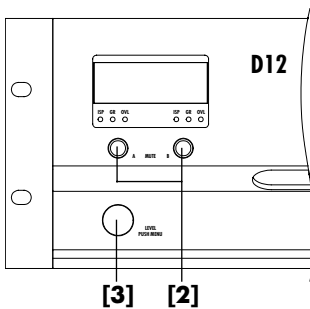

Fig. 6: D12 Controls

- **Regular short flashes** (1:8 duty cycle): ⇒ **STANDBY:**
in standby mode the loudspeaker outputs are electronically isolated and the D12 idles, drawing minimal mains power. Only the most essential functions are provided. Display and network remain functional, the display illumination is switched off after 10 seconds. Pressing the MUTE A or B switch powers on the D12 ready for use. The D12 may also be powered back on by remote control from standby mode.

Note: When the D12 is set to STANDBY (or the mains power is turned off) the movement of the loudspeaker cones in the cabinets connected is no longer damped by the power amplifier output. This removal of the damping makes them susceptible to excitation by other loudspeakers in the surroundings. Audible resonances may occur, and even absorption of low frequency sound energy as the undamped loudspeakers act like a "bass trap". To permanently mute single subwoofer cabinets when others are operated at the same time it is therefore preferable to use the MUTE function instead of STANDBY. The STANDBY mode, however, can be of advantage with mid/high systems, because it will remove any residual noise from the system.

4.1.3. LEVEL/PUSH MENU (Digital rotary encoder) [3]

Operation, configuration and status viewing of the D12 are all accessed via the front panel digital rotary encoder - LEVEL/PUSH MENU. In the main menu the encoder acts as a level control. Pushing or turning the encoder gives access to different menu levels or enables configurations or values to be entered.

- **Brief press:** alternating between level control of channel A or B.
- **Long press** (approx. 1 sec.): access to the menu level.

Note: A detailed description of the D12 menu structure and access is given in the D12 Software manual, which is also provided with the D12.

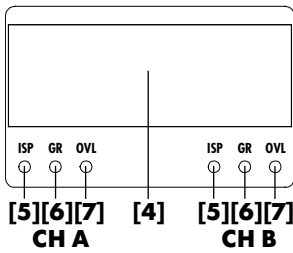

Fig. 7: D12 Indicators in detail

IMPORTANT!

4.2. Indicators

4.2.1. LC Display [4]

Serves as a user interface and display for all configuration settings and status information.

The display is illuminated and can be set to "on/off/timeout 10 s."

A detailed description of the menu structure and access is given in the D12 Software manual, which is also provided with the D12.

4.2.2. ISP LED (A/B) - Input Signal Present (green) [5]

- **Input - analog**

Illuminates when the D12 input signal exceeds -30 dBu: the ISP indication is unaffected by the setting of the level control and the MUTE function but will not operate in STANDBY mode.

- **Input - digital (AES/EBU)**

Illuminates when the D12 digital input is locked to 48 or 96 kHz and the signal exceeds -57 dBFS

(FS = Full Scale): the ISP indication is unaffected by the setting of the level control and the MUTE function but will not operate in STANDBY mode.

Notes on the digital AES/EBU input \Rightarrow Sampling rates

The two sampling rates 48/96 kHz are supported by the digital AES/EBU input of the D12.

Other (standard) sampling rates (e.g. 32/44.1 or 88.2 kHz) will be detected but not supported.

Non standard sampling rates will be ignored.

4.2.3. GR LED (A/B) - Gain Reduction (yellow) [6]

- **Illuminates depending on the input signal:** the D12 limiter circuit reduces gain by more than 3 dB.

This state is not critical but shows that the system has reached its limits.

4.2.4. OVL LED (A/B) - Overload (red) [7]:

- **Illuminates depending on the input signal \Rightarrow Overload:** either the input signal level is too high, gain reduction exceeds 12 dB or the D12 is trying to deliver too high an output current. If in doubt reduce the input gain at the D12 level control. If the error message disappears, the output current has been too high (load impedance too low caused by too many loudspeakers connected to the D12 output, or a defective cable or connector). If the condition does not change, the input signal to the D12 is too high (greater than $+25$ dBu).

An overload could also be caused by accumulating the source input A+B or by high gain settings (boosts) in the single EQ bands, while the input signal is lower than $+25$ dBu.

- **Flashes (1:1 mark space) \Rightarrow Error:** an error message will be displayed altering with the device name.

5. Connections

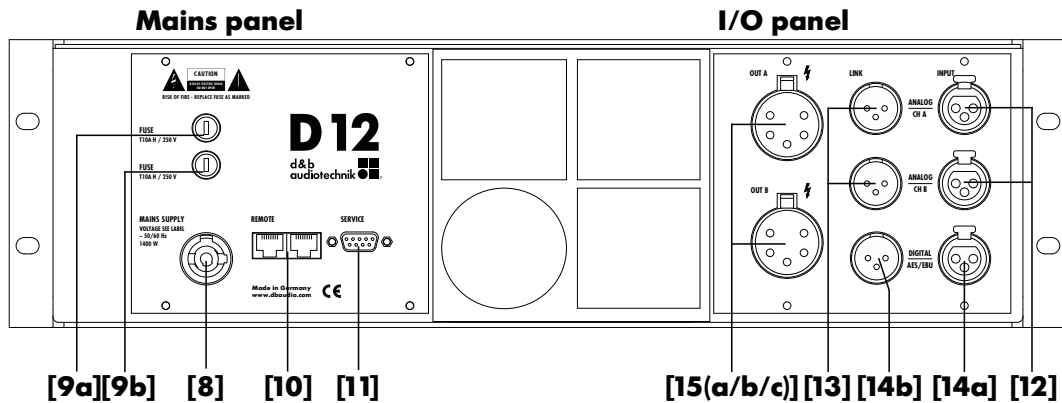

Fig. 8: D12 Connections

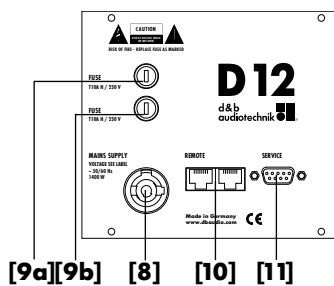

Fig. 9: D12 Mains panel



WARNING!

IMPORTANT!



WARNING!

5.1. Mains panel

A PowerCon mains connector [8] is fitted on the rear panel and an appropriate mains lead is supplied.

Two RJ45 [10] connectors are also provided for the D12 REMOTE functions.

A D-SUB-9 SERVICE connector [11] is fitted which allows operating software and loudspeaker configuration updates to be loaded into the unit.

5.1.1. Mains power connection [8]

Only connect the D12 to mains power supplies with a ground conductor (protective earth).

Make absolutely sure that earth is connected correctly.

Before connecting the device to mains voltage, check that the mains voltage and frequency corresponds to the specifications on the configuration sticker on the rear of the D12.

5.1.2. Fuse protection [9 (a/b)]

If a fuse has failed disconnect the D12 from the mains power supply before replacement.

Only use a fuse of the correct type – 5 x 20 mm/high breaking capacity - and nominal current value. The current value can be read from the rear mains panel beside the respective fuse.

The mains fuses are located above the PowerCon socket and fulfill a purely protective function in case of a device fault. They do not serve as an overload protection.

In 200/230 V operation the upper fuse works only [9a]. In 100/115 V operation both fuses are working [9a and b].

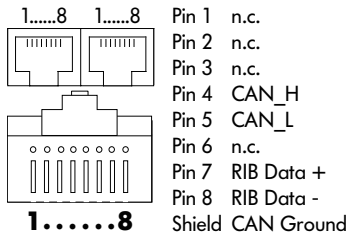

Fig. 10: Pin assignment for remote control (RJ45)

5.1.3. REMOTE [10]

The D12 is fitted with a 2-wire serial remote control interface, (2 x RJ 45) carrying both the RIB and CAN-Bus signals. All pins of both connectors are wired in parallel allowing either to be used as the input or output. Where remote control networking conforms to a "Bus or Ring topology" one connector is used for the incoming signal and the second connector allows for direct connection to another device (daisy chaining) or for terminating in the case of a CAN-Bus network. The interface connections for the RIB (pin 7/8) are opto-coupled, while the connections for the CAN-Bus (pin 4/5) are hard wired to common ground (protective earth).

Pin	Signal	Remark
1	-	
2	-	
3	-	
4	CAN_H	CAN high bus line (active high)
5	CAN_L	CAN low bus line (active low)
6	-	
7	RIB Data +	
8	RIB Data -	
Shield	GND	CAN Ground

Tab. 4: RJ45 pin assignment on d&b devices

Regarding the CAN-Bus network shielded cables and shielded RJ45 connectors must be used while the cable shielding must be connected to both sides of the RJ45 connector as the "CAN Ground" is routed via the cable shielding.

IMPORTANT!

Note:

A detailed description of remote control via dbCAN (CAN-Bus) is given in the technical information TI 312 (d&b code D5312.E).

5.1.4. SERVICE [11]

The D-SUB-9 SERVICE interface (RS 232 female) allows operating software and loudspeaker configuration updates to be loaded into the unit.

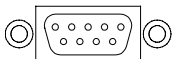

Fig. 11: SERVICE connector (D-SUB-9)

IMPORTANT!

To connect the computer to the SERVICE connector a standard RS-232 connection cable (D-SUB-9 serial cable female/male - 1:1) must be used (serial extension cable).

Pin	Signal	Remark
2	RxD	
3	TxD	
5	GND	Signal ground

Tab. 5: D-SUB-9 pin assignment on d&b devices

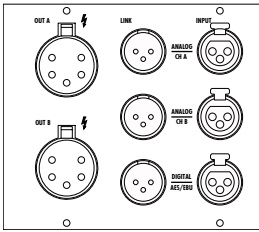

Fig. 12: D12 I/O Panel

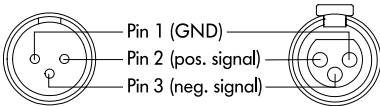

Fig. 13: Pin assignment D12 ANALOG INPUT/LINK

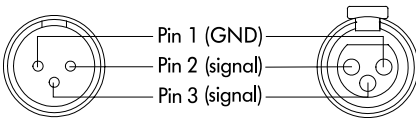

Fig. 14: Pin assignment D12 DIGITAL INPUT/LINK

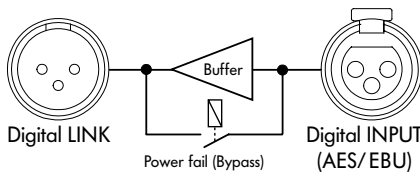

Fig. 15: D12 Digital INPUT and LINK

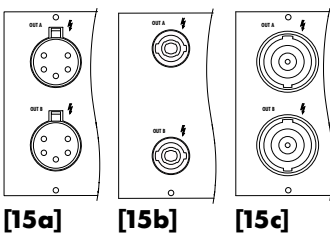

Fig. 16: D12 EP5 [15a], NL4 [15b] or NL8 [15c] output connectors

5.2. Connector panel (I/O Panel)

All signal input and output connections are located on the rear I/O panel.

These include analog and digital (AES/EBU) signal inputs and link outputs for each channel. Loudspeaker outputs are optionally either EP5, NL4 or NL8, dependent on the loudspeaker input version or type.

5.2.1. INPUT A/B [12] and LINK A/B [13]

A 3 pin female XLR input connector is provided for channel A and B.

Wired in parallel is a 3 pin male XLR input link connector used to feed the input signal on to the next device in the system signal chain.

5.2.2. INPUT DIGITAL AES/EBU [14a] and LINK [14b]

A 3 pin female XLR AES/EBU (AES 3) input [14a] and a 3 pin male XLR LINK output [14b] is provided.

The balanced input utilizes a transformer and is electrically isolated.

The digital LINK output may be used to feed a refreshed input signal to the next device in the system signal chain. The signal shape (the rising and trailing edges of the signal) and level are refreshed with an analog signal amplifier.

A power fail relay is incorporated to prevent interruption of the signal chain should there be a power failure. In this situation, the digital input signal bypasses the analog buffer amplifier and is routed directly to the LINK output.

5.2.3. OUT A/B [15 (a/b/c)]

The D12 amplifier is supplied with EP5, NL4 or NL8 output connectors as an option.

The pin assignment for the loudspeaker output connectors is automatically switched depending on the I/O mode selected.

5.2.4. D12 I/O modes

There are three different output modes:

1. **Dual channel mode**
2. **Mix TOP/SUB mode**
3. **2-Way Active mode**

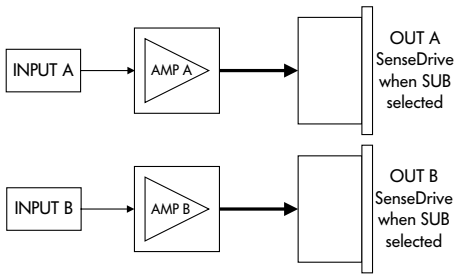

Fig. 17: D12 Input/Output routing Dual channel mode with standard input routing

5.2.4.1. Dual channel mode

In "Dual channel mode" the D12 acts as a two channel amplifier – stereo amplifier. The amplifier channels are connected to their respective output connectors (AMP Ch A to OUT A and AMP Ch B to OUT B). Each output connector is wired in parallel using the respective pins for TOP or SUB configurations (refer to section 5.2.5.1. Loudspeaker pin assignments and equivalents on page 20).

The "Dual channel mode" is dedicated to all d&b fullrange systems (passive systems) and M4, MAX/MAX12 in passive mode and the active driven d&b subwoofers. Both channels could be configured for TOP or SUB cabinets independently.

Applicable loudspeaker set ups on either channel:

Q/Qi-Series	B1/B2-SUBs
C-Series w/o C3	MAX (MAX/MAX12 passive)
Ci-Series w/o Ci3	M4 (passive)
E-Series	Linear

In "Dual channel mode" the SenseDrive function is available for applicable cabinets on channel A and B (with EP5 or NL8 connectors only).

Ensure that the connected type of loudspeaker is corresponding with the actual configuration of the D12.

In "Dual channel mode" all four pins (TOP and SUB) are driven. This could cause damage to TOPs when a SUB configuration is selected on the respective channel.

The D12 will monitor the current through the different output pins and will detect if a wrong cabinet type is connected. Depending on the setting of the D12 the error message "**Top/Sub-Mismatch**" will be given out on the LCD and the respective channel will be muted. Please refer to the D12 Software manual section under "D12 Settings menu – Options – TSM Detection (Top/Sub-Mismatch)".

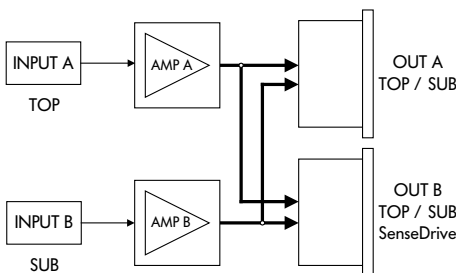

Fig. 18: D12 Input/Output routing Mix TOP/SUB mode with standard input routing

5.2.4.2. Mix TOP/SUB mode

In "Mix TOP/SUB mode" Both amplifier channels are connected to both output connectors (AMP Ch A and Ch B to OUT A and B). The output connectors are wired in parallel using the respective pins for TOP and SUB configurations. (refer to section 5.2.5.1. Loudspeaker pin assignments and equivalents on page 20)

The "Mix TOP/SUB mode" is dedicated to all d&b fullrange systems (passive systems) and M4, MAX/MAX12 in passive mode together with active driven d&b subwoofers while TOP cabinets (set ups) are selectable on channel A and SUB cabinets (set ups) on channel B.

Applicable loudspeaker set ups:

Channel A	Channel B
Q/Qi-TOPs	Q/Qi-SUBs
C-TOPs w/o C3	C/Ci-SUBs
Ci-TOPs w/o Ci3	B1/B2-SUBs
E-TOPs	E-SUBs
MAX (MAX/MAX12 passive)	
M4 (passive)	
Linear	

In "Mix TOP/SUB mode" the SenseDrive function is available for applicable cabinets on channel B (with EP5 or NL8 connectors only).

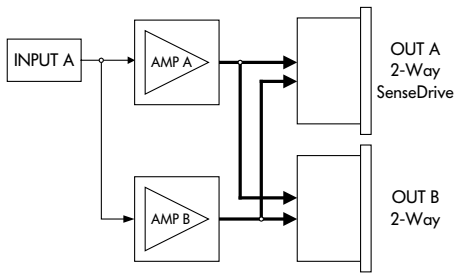

Fig. 19: D12 Input/Output routing 2-Way Active mode with standard input routing

5.2.4.3. 2-Way Active mode - Single input

In "2-Way Active mode" both amplifier channels are connected to both output connectors (AMP Ch A and B to OUT A and B) while The loudspeaker cabinets (set ups) are selectable on Channel A. All settings of channel A and the input signal are linked to channel B and can not be configured individually.

The "2-Way Active mode" is dedicated to the d&b active systems F1222, M2 and C3 as well as for M4 and MAX/MAX12 when driven actively.

Applicable loudspeaker set ups:

J-Series	M2
C3/Ci3	M4 active
F1222	MAX active

In "2-Way Active mode" the SenseDrive function is available for applicable cabinets on Channel A (with EP5 or NL8 connectors only).

5.2.5. Loudspeaker wiring

Note: For further and detailed information regarding the connector wiring of the respective loudspeaker please refer to its corresponding manual.

The passive full range/TOP systems and passive subwoofers use pins 1 and 2 of the EP5 connector (1+ and 1- of the NL4 connector).

Active driven subwoofers use pins 3/4 and pin 5 of the EP5 connectors (2+ and 2- of the NL4 connector).

	EP5	NL4
TOP+	1	1+
TOP-	2	1-
SUB+	3	2+
SUB-	4	2-
SenseDrive SUB	5	n.a.

Tab. 6: TOP/SUB pin assignments of EP5/NL4 connectors

These pin assignments allow full range cabinets and subwoofers to be linked together and connected to the amplifier in mixed configuration (Mix-TOP/SUB) using a single 4 or 5-wire cable. SenseDrive is only available when using EP5 connectors and 5-wire cables.

5.2.5.1. Loudspeaker pin assignments and equivalents

Q/Qi/C/Ci/E-TOPs

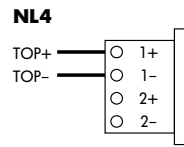
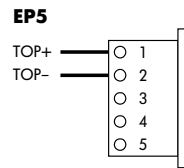

Q/Qi/C/Ci/E/ B-SUBs

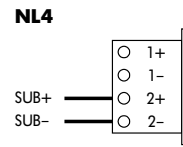
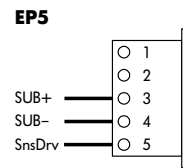

NL8 (B1/B2-SUB)

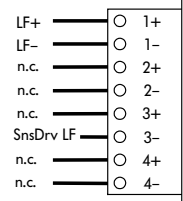

C3/Ci3/MAX/M4

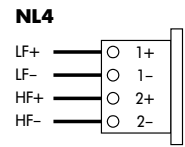
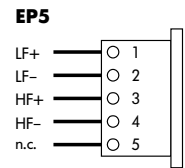

M2/F1222

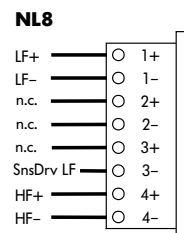
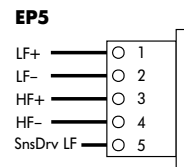

J8/J12

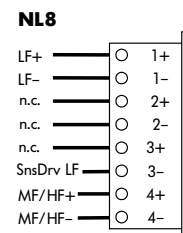
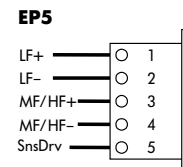

J-SUB

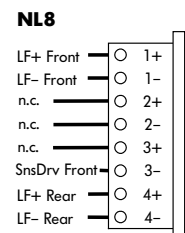
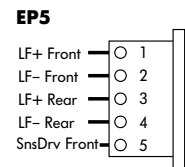

Fig. 20: Loudspeaker pin assignments and equivalents

6. Installation and operation

6.1. Installation

D12 amplifier enclosures are designed to fit a standard 19" equipment rack or cabinet.

The front panel vent slot serves as a useful handle for lifting and moving amplifiers in and out of racks. When specifying a rack, be sure to allow extra depth (10 cm / 4" is usually sufficient) to accommodate the cables and connectors at the rear of the amplifier(s).

When mounting amplifiers into a 19" rack cabinet, provide additional support using shelves fixed to the inner sides of the cabinet or the mounting holes provided on the amplifier rear mounted rack ears - do not just rely on fixing and supporting amplifiers by their front panels. This advice is particularly important if amplifiers are being racked up for touring use.

Since the D12 amplifier can generate a lot of heat, please ensure, whatever the mounting or racking arrangement, that adequate cool airflow is provided to avoid a build-up of hot air inside the rack leading to overheating. When setting up the amplifier, do not block or cover the rear panel air intake or the vents on the front panel of the amplifier - see Fig. 21.

We advise frequent cleaning of the fan filter to ensure good airflow through the unit. If the filter is visibly dirty, then it should be cleaned or replaced - see Fig. 22. Never operate the D12 without a filter. Dust deposits, especially combined with damp conditions, could cause the amplifier to malfunction. If amplifiers are installed in cabinets so that direct access to the rear panel filters is not possible, we recommend using additional fan modules with front mounted filters that can be easily replaced without opening the sealed cabinets.

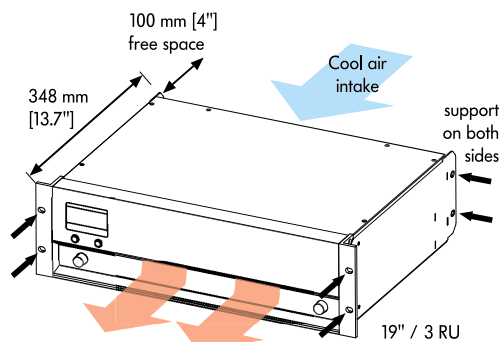

Fig. 21: D12 Installation

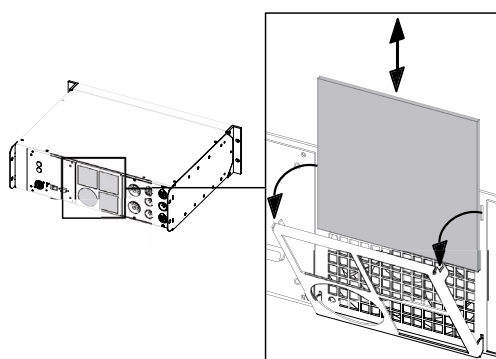

Fig. 22: D12 Fan filter exchange

6.2. Operation

6.2.1. Power consumption and power loss

The power required from the mains supply and the waste heat produced by the amplifiers power loss vary depending on the load impedance and the signal levels and characteristics (e.g. speech, music).

In practice, the theoretical peak power consumption of a system will only be sustained for a short period of time. Basing mains current and air conditioning plant requirements on the peak power consumption of the sound system would result in a generously over-specified installation. The key factor in power consumption calculations is the crest factor (CF) of the music or speech signal - the ratio of peak to sustainable RMS voltage of the signal.

A crest factor of 2.4 represents 1/3 of the maximum sine output power and it can be seen as the worst case signal that can be accessed in real world conditions. A proper power distribution should be able to handle the current ratings given in the table below (Tab. 7) referring to CF 2.4. Using the D12 temporarily with well known signals of higher crest factor, the power distribution can be downsized within the range given in the table.

The table gives power figures for various types of signal waveforms. They were measured on a D12 driving a 4 ohm load (both channels) to the clipping point of both channels using a sine wave burst signal of 24 dBu with a variable duty cycle. The mains power supply used for the measurements supplied an ideal sine wave with 230 V/50 – 60 Hz at an internal resistance of 0.5 ohms (0.12/0.1 ohms for 115/100 V) equivalent to a mains lead of 20 m (65.6 ft) with a cross section of 1.5 mm² (6 mm² / 8 mm² for 115/100 V).

Signal waveform	CF	Duty	P _{out} [W]	P _{in} [W]	P _{loss} [W]	I _{in(230V)} [A]	I _{in(115V)} [A]	I _{in(100V)} [A]
Highly compressed music*	2.4	1 : 3.3	800	1230	430	9.2	18.4	20.2
Music with low dynamic range	3.5	1 : 7	400	640	240	5.3	10.6	11.2
Music with wide dynamic range	5.0	1 : 14	200	360	160	3.2	6.4	7.0

Tab. 7: D12 Power balance

Key:

CF: Crest factor, **Duty:** Duty cycle, **P_{out}[W]:** Max. average output power (sum of both channels), **P_{in}[W]:** Input power (effective power)

P_{loss}: Power loss (thermal power), **I_{in(XXXV)}[A]:** Resulting current,

* Maximum practice operation

6.2.2. Operating conditions

The following diagram shows the thermal operating range within which the technical data will be maintained. The operation beyond this range is possible for a short time and for thermal reasons this will trigger the amplifier protection circuit into thermal overload.

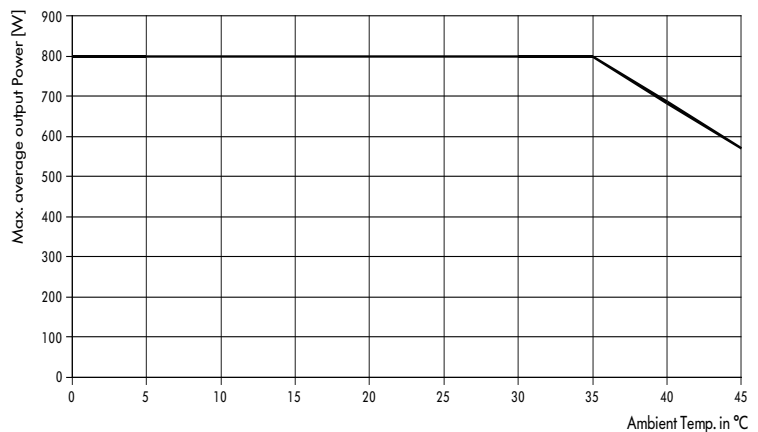

Fig. 23: Average maximum total output power vs. ambient temperature

As explained in section 6.2.1, a worst case signal with a CF of 2.4 is producing 1/3 of the rated sine output power or 400 watts at 4 ohms per channel (800 watts total). The thermal management of the D12 is designed to deliver this power for an unlimited amount of time within an ambient temperature of up to 35 °C (95 °F). With higher ambient temperatures, the maximum average output power that can be delivered without entering thermal protection, is reducing linearly as shown in the diagram.

When using the D12 at its upper temperature limit of 45 °C (113 °F), the maximum continuous output power is 500 watts total or 250 watts per channel. Again referring to section 6.2.1 - (Tab. 7) - the unit will work properly with e.g. 400 watts total when either running 4 ohms loads when the signal has a CF of 3.5 or running 8 ohms loads if the worst case signal with a CF of 2.4 needs to be handled.

The maximum possible output power of 2 x 1200 W at 4 ohms, which for thermal reason could only be supplied in a short term (within minutes), is unaffected by the ambient temperature.

6.2.3. Mains supply

Number of devices per phase conductor when full output power is required.

Mains supply	Number of devices
230 V / 16 A	Max. 2
115/100 V / 15 A	Max. 1

Tab. 8: Mains supply and number of devices

In the USA and Japan we recommend the operation over two phase conductors (phase to phase – 240/200 V) or the use of mains leads with a much higher cross section (min. 4 mm² / AWG 12).

7. Technical specifications

Displays

ISP A/B.....	Input Signal Present indicator (green)
GR A/B.....	Gain Reduction indicator (yellow)
OVL A/B.....	Overload/Error indicator (red)
MUTE A/B.....	Mute/Standby indicator (green)
Liquid Crystal Display (LCD).....	Graphic display / 120 x 32 Pixel

Controls

POWER.....	Main power switch
MUTE A/B.....	Mute/Standby switch
LEVEL/PUSH MENU.....	Digital rotary encoder; access to all functions (Channel A/B) including:
Level control.....	- 57.5 dB ... +6 dB with 0.5 dB detents
Filter configurations.....	Up to three loudspeaker specific filter circuits (e.g. CUT/HFA/HFC)
Equalizer.....	Optional 4-band parametric equalizer/Notch
Delay setting.....	0.3 - 340 msec. with 0.1 msec. detents
System set ups.....	All current d&b loudspeakers/linear (MAX/MAX12)
Channel coupling.....	common access to Delay, Equalizer, Delay+Equalizer
Protection.....	Operator input inhibit/password protection
Remote control.....	dbCAN/RIB
Device name.....	15 alphanumeric digits
Display illumination.....	Off/On/Timeout 10 sec.
Frequency generator.....	Pink Noise or Sine wave, 10 Hz - 20 kHz with 1 Hz detents Level: - 57.5 dB ... +6 dB with 0.5 dB detents
Buzzer.....	Audible signal for error messages

Connectors

INPUT ANALOG CH A / CH B.....	3 pin XLR female pin assignment: 1 = GND, 2 = pos. Signal, 3 = neg. Signal
Input impedance.....	44 kOhm, electronically balanced
Common mode rejection (CMRR, 20 Hz - 20 kHz).....	> 63 dB
Maximum input level.....	+25 dBu
LINK ANALOG CH A / CH B.....	3 pin XLR male pin assignment: 1 = GND, 2 = pos. Signal, 3 = neg. Signal parallel to INPUT
INPUT DIGITAL AES/EBU.....	3 pin XLR female, AES 3 pin assignment: 1 = GND, 2 = Signal, 3 = Signal
Input impedance.....	110 ohms, transformer balanced
Sampling.....	48 kHz / 96 kHz / 2 Ch/n
Synchronisation.....	Word-Sync: PLL-locked to source (slave mode)
LINK DIGITAL (Output).....	3 pin XLR male electronically balanced analog signal buffering (refresh) Power Fail Relay (Bypass)
OUT A/B.....	EP5 / NL4 / NL8 dependent on the loudspeaker input version or type
REMOTE.....	2 x RJ 45 parallel
SERVICE.....	D-SUB-9 female

Protection circuits

Mains inrush current limiter.....	5 A RMS at 230 V
.....	10 A RMS at 115/100 V
Speaker switch on delay.....	Approx. 2 sec.
Oversvoltage protection.....	Up to 400 VAC
Self-resetting overtemperature protection.....	75 °C / 167 °F
Output short and open circuit protection.....	± 60 A peak
Overload protection amplifier output.....	SOA of the output stage

Audio data (linear setting with subsonic filter)

Rated output power (THD + N 0.1%).....	2 x 750 W into 8 ohms both channels are driven
.....	2 x 1200 W into 4 ohms both channels are driven
Frequency response (-1 dB).....	28 Hz - 40 kHz
THD+N (20 Hz - 20 kHz).....	< 0.1 %
IM (SMPTE).....	< 0.1 %
S/N ratio (unweighted, RMS).....	>110 dB
Damping factor (20 Hz - 1 kHz into 4 ohms).....	>200
Crosstalk (20 Hz - 20 kHz).....	< - 65 dB
Digital Signal Processing	
Sampling rate:.....	96 kHz / 27 Bit ADC / 24 Bit DAC
Basic delay.....	0.3 msec.
ADC dynamic.....	> 110 dB
Input dynamic.....	> 127 dB
DAC dynamic.....	> 110 dB

Power supply

Autosensing switched mode power supply for mains voltages 115/230 V
(optional 100/200 V), 50 - 60 Hz.

Mains connector.....	PowerCon (blue)
Mains voltage 115/230 V (min./nom./max.).....	98/115/134 V, 50 - 60 Hz low range
.....	195/230/265 V, 50 - 60 Hz high range
Mains voltage 100/200 V (min./nom./max.).....	85/100/117 V, 50 - 60 Hz low range
.....	170/200/234 V 50 - 60 Hz high range
Mains fuse.....	2 x 10 A Time lag (T) 5 x 20 mm, high breaking capacity

Operating conditions

Temperature range*.....	5°C - 35 °C / 41 °F - 95 °F
*sum of average output power of 2 x 400 W (800 W) into 4 ohms for continous operation	
Temperature range**.....	5 °C - 45 °C / 41 °F - 113 °F
**reduced output power or short term operation	
Humidity (rel.), average.....	70 %

Dimensions and weight

Height x width x depth.....	3 RU x 19" x 353 mm
.....	3 RU x 19" x 13.9 "
Weight.....	13 kg / 28.7 lb

7.1. Technical drawings

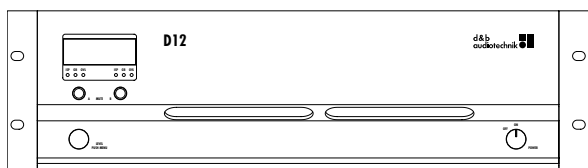

Fig. 24: D12 front view

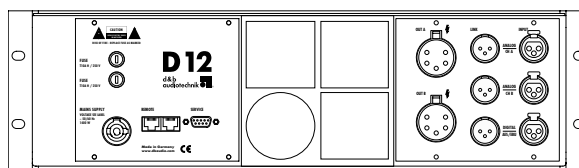

Fig. 25: D12 rear view

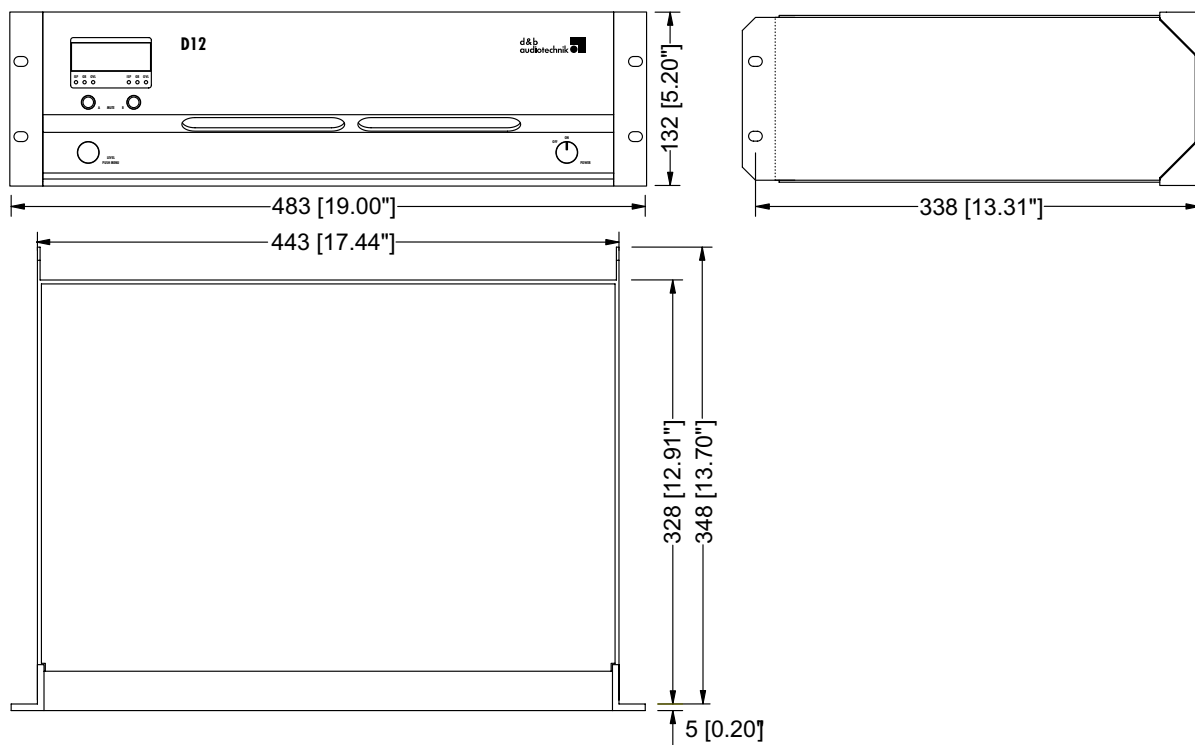

Fig. 26: D12 enclosure dimensions in mm [inch]

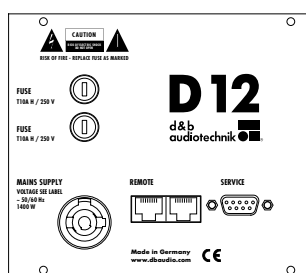

Fig. 27: D12 mains panel

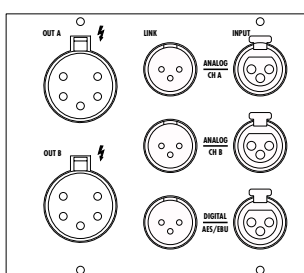

Fig. 28: D12 I/O panel EP5

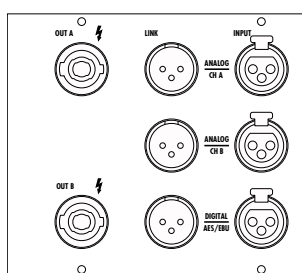

Fig. 29: D12 I/O panel NL4

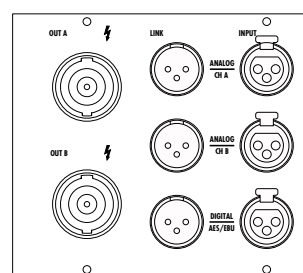

Fig. 30: D12 I/O panel NL4

8. Declarations



8.1. EU declaration of conformity (CE symbol)

This declaration applies to the D12 amplifier manufactured by d&b audiotechnik AG consisting of the amplifier unit.

- **D12, Z2600.000/001**

- **D12, Z2600.300/301**

All products of type D12 starting from variant Z2600.000 are included, provided they correspond to the original technical version and have not been subject to any later design or electromechanical modifications.

We herewith declare that said products are in conformity with the provisions of the following EC directives including all applicable amendments:

- 2006/95 Low Voltage
- 89/336 Electromagnetic Compatibility

The following standards have been applied:

- DIN EN 60065:1998
- DIN EN 55103-1:1996, classes E1 bis E4
- DIN EN 55103-2:1996, classes E1 bis E4

